



Visualization Software for Computer Systems Organization and Architecture

John D. Carpinelli

New Jersey Institute of Technology

Software Design Goals

- Concentrate on visual aspects of simulation
- Interactive component
- Simplified simulations to explain basic concepts
- Work in conjunction with the textbook *Computer Systems Organization and Architecture*

Software Design Standards

- All simulators coded as Java applets
 - Platform independent
 - Accessible using any Java-enabled web browser
 - Promotes code reuse
- All simulators and source code freely available under the GNU Public License

Relatively Simple CPU Simulator - Features

- Fixed architecture, 16-instruction CPU
- Animates data flow within the CPU
- Hardwired or microcoded control unit
- Simulates execution of user specified assembly language program
- Single step, breakpoint, or continuous execution

Relatively Simple CPU – Register Section

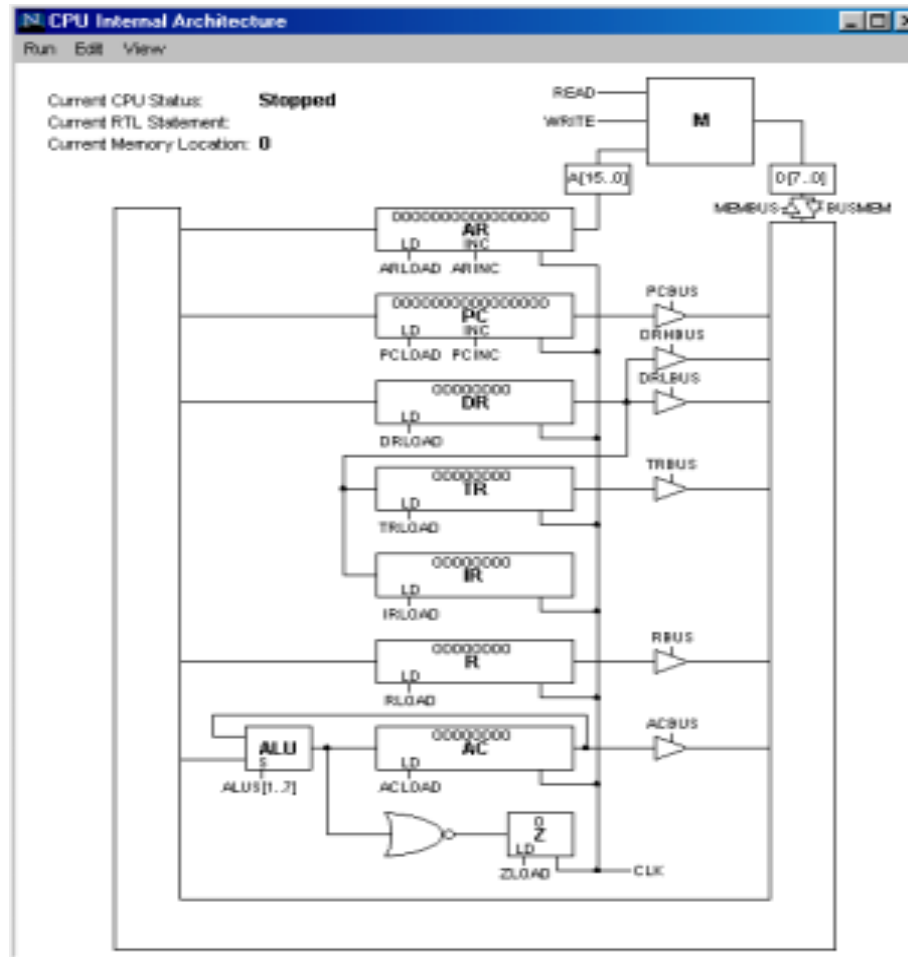

Relatively Simple Computer Simulator - Features

- Fixed system architecture: Relatively Simple CPU, memory, I/O port
- Animates data flow between components
- Simulates execution of user specified assembly language program
- Single step, breakpoint, or continuous execution; trace option available

Relatively Simple Computer System - Architecture

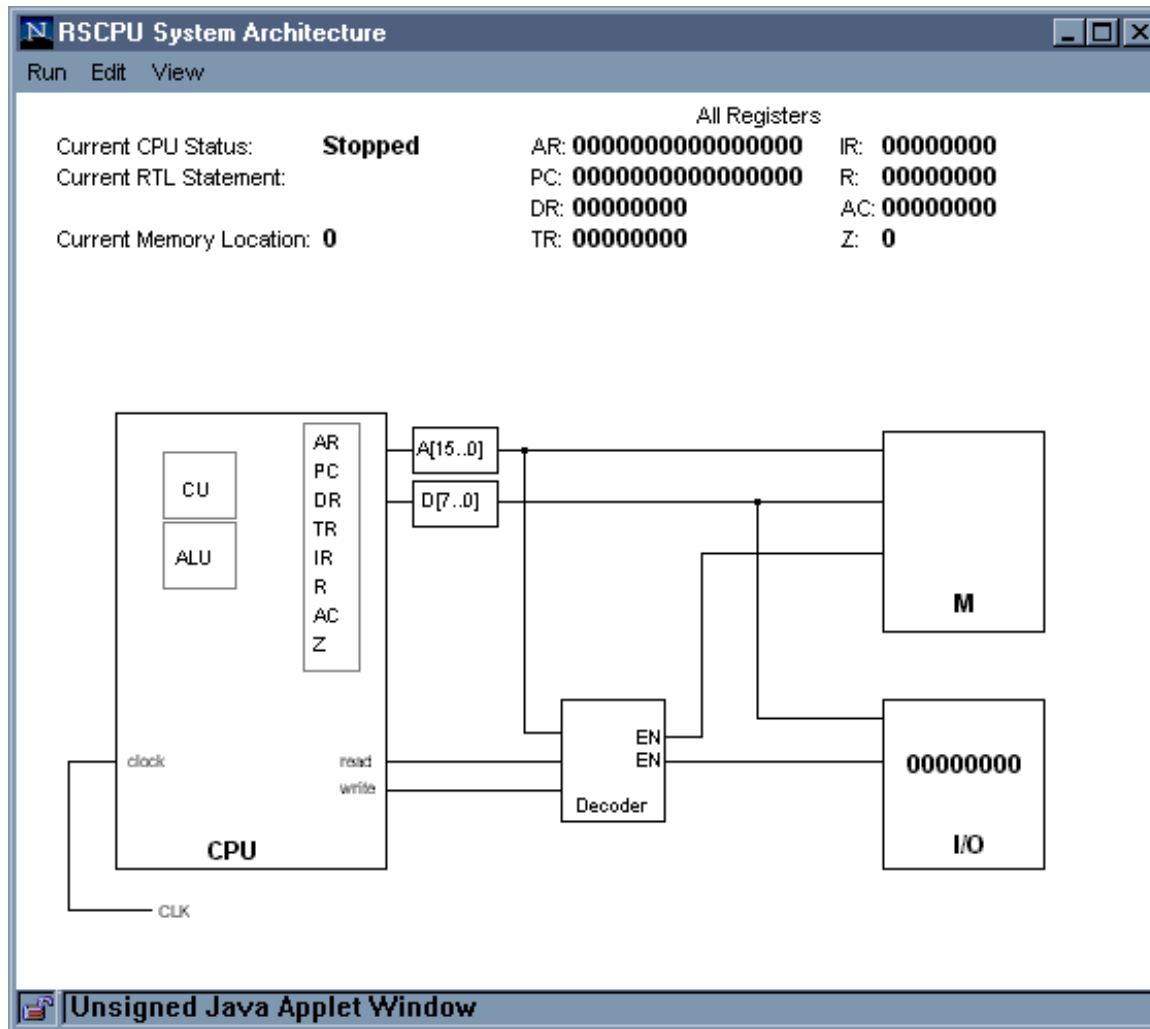

PLD Visualization Tool - Features

- More visualization than simulation
- Up to four inputs and four outputs
- User makes and breaks PLD connections
- Output functions displayed: updated as connections are changed

PLD Visualization Tool - Organization

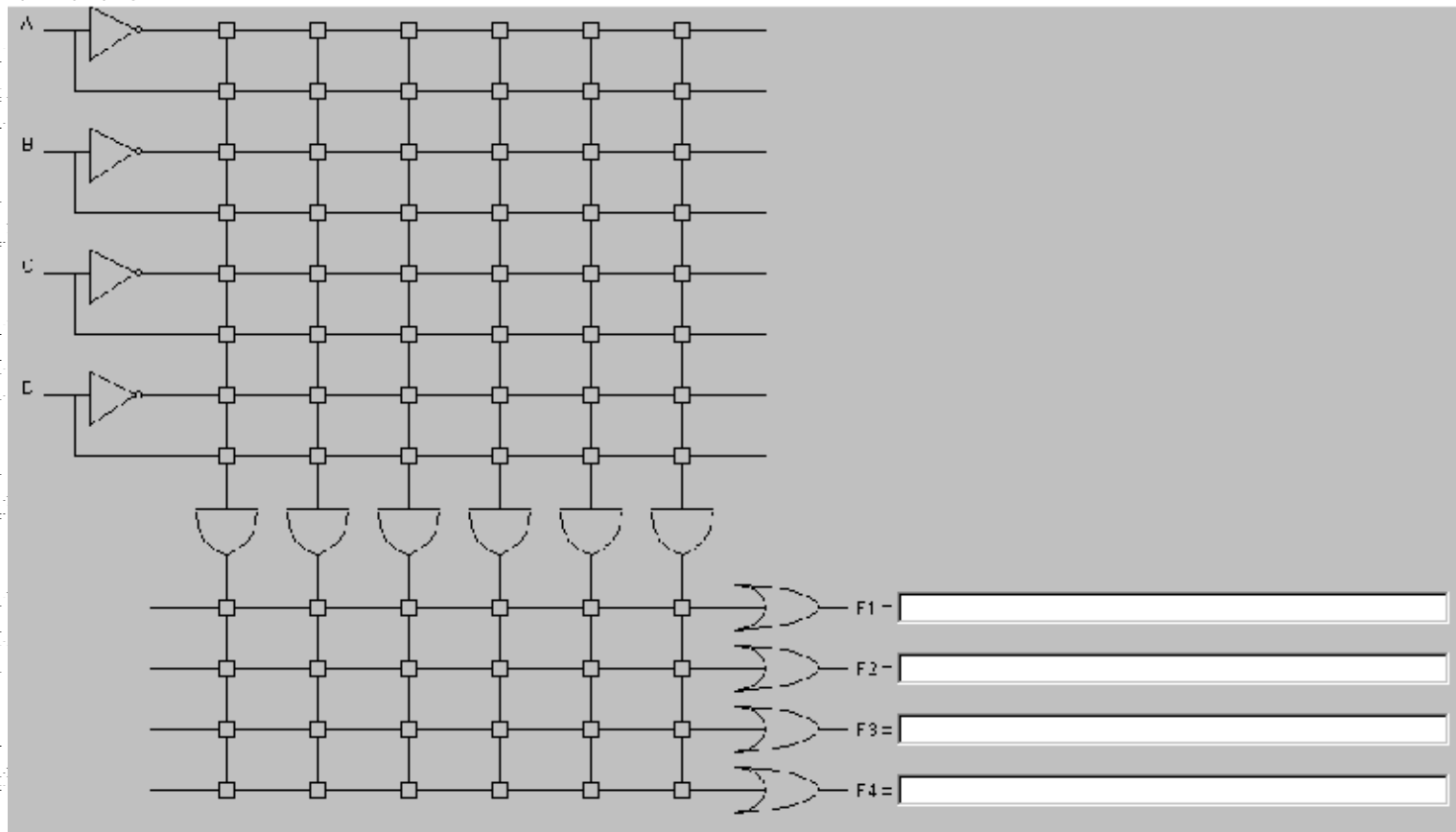

Future Development Plans

- Very Simple CPU Simulator
- DMA Controller Simulator
- Computer Arithmetic Hardware Simulator
- Cache Memory Simulator
- Virtual Memory Simulator